



# Center Partition Worksheet / Order Form # 081601

<b>F/G Products, Inc.</b> 3000 Pioneer Ave Rice Lake, WI 54868	(715) 234-2334 (800) 247-3854 Fax (715) 736-0989 E-mail sales@fgproducts.com	<b>Location:</b> _____ <b>End User:</b> _____ <b>System in Plant Date:</b> _____	<b>Quantity of Trailers:</b> _____ <b>PO#:</b> _____ <b>Job#:</b> _____
--	---	--	---

**1. Trailer Manufacture / Model:** \_\_\_\_\_

**New Trailer/Body:** \_\_\_\_\_  
**Existing Retro Fit:** \_\_\_\_\_  
**Trailer/Body Length:** \_\_\_\_\_'  
**Trailer Body Width:** \_\_\_\_\_"

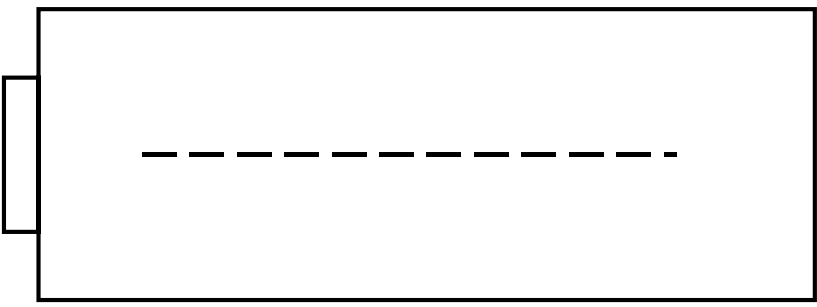

**2. Type of Rear Door:** Swing \_\_\_  
 Roll-Up \_\_\_  
 Roll-Up/Cavity \_\_\_

**3. Evaporator Model:** \_\_\_\_\_

**4. Would you like your Center Partition System**  
 Moveable: \_\_\_\_\_ Fixed: \_\_\_\_\_

**6. Does the partition go all the way to the front wall?** Yes \_\_\_ No \_\_\_

**5. What is the overall length you require?** \_\_\_\_\_"

**7. Sketch Preferred Layout including Remotes & Side Door Locations (Dashed line is only a guide)**

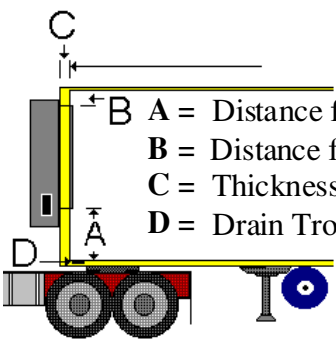

### FRONT WALL SPECIFICATIONS

**A** = Distance from top of floor to bottom of evaporator \_\_\_\_\_"  
**B** = Distance from top of evaporator to ceiling \_\_\_\_\_"  
**C** = Thickness of front wall of the trailer \_\_\_\_\_"  
**D** = Drain Trough Dimensions: Depth (*top of floor to bottom of trough*) \_\_\_\_\_"  
 Width (*floor to front wall*) \_\_\_\_\_"

**Thermo King**  
 \_\_\_\_\_ SBIII DE  
 \_\_\_\_\_ SBIII TCI

**Carrier**  
 \_\_\_\_\_ TM-900  
 \_\_\_\_\_ TM-1000  
*(Return Air Bulkhead F/G Manufactured, Carrier Supplied)*

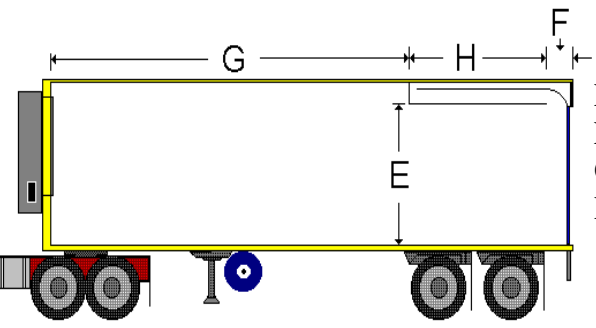

### ROLL-UP DOOR CAVITY SPECIFICATIONS

**E** = Height from top of floor to false ceiling \_\_\_\_\_"  
**F** = Distance from rear of false ceiling to rear of the trailer \_\_\_\_\_"  
**G** = Distance from front wall to leading edge of false ceiling \_\_\_\_\_"  
**H** = Length of false ceiling cavity \_\_\_\_\_"

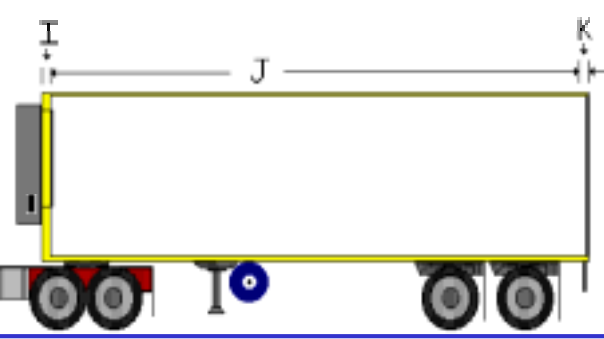

### SWING DOOR SPECIFICATIONS

**I** = Thickness of front wall of the trailer \_\_\_\_\_"  
**J** = Distance from front wall to inside of doors \_\_\_\_\_"  
**K** = Distance from inside of door to outside of door frame \_\_\_\_\_"



# Center Partition Worksheet / Order Form # 081601

F/G Products, Inc.  
3000 Pioneer Ave  
Rice Lake, WI 54868

(715) 234-2334  
(800) 247-3854  
Fax (715) 736-0989  
E-mail sales@fgproducts.com

Location: \_\_\_\_\_  
End User: \_\_\_\_\_  
System in Plant Date: \_\_\_\_\_

Quantity of Trailers: \_\_\_\_\_  
PO#: \_\_\_\_\_  
Job#: \_\_\_\_\_

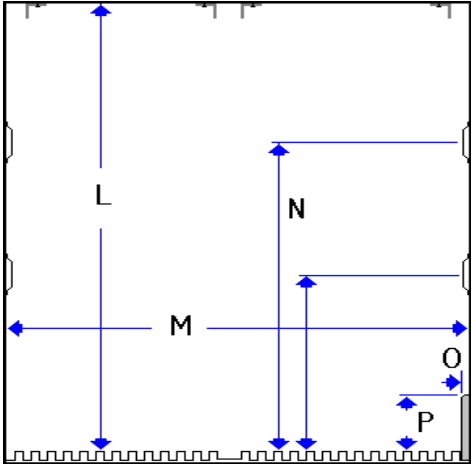

## INTERIOR DIMENSIONS

**L** = Inside Height \_\_\_\_\_"  
**M** = Inside Width \_\_\_\_\_"  
**N** = Logistic Track Locations (30" and 60" are Standard)  
     Pushed-In Style \_\_\_\_\_  
     Pan Style \_\_\_\_\_  
     *If different ~ please call for a quote \_\_\_\_\_" & \_\_\_\_\_"*  
**O** = Scuff Width \_\_\_\_\_"  
**P** = Scuff Height \_\_\_\_\_"

## TROUGH SPECIFICATIONS

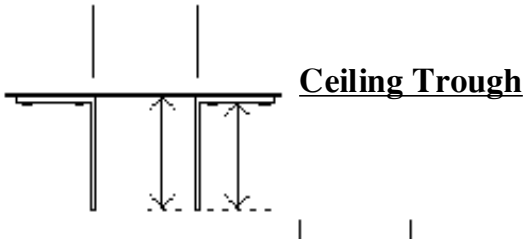

Please fill in your Trough Dimensions.

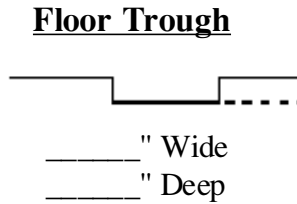

Please fill in your Trough Dimensions.

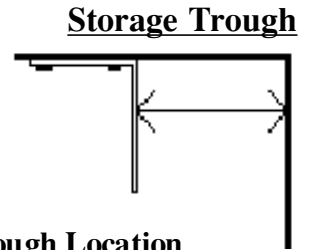

**Storage Trough Location**

- \_\_\_\_\_ Curbside
- \_\_\_\_\_ Roadside
- \_\_\_\_\_ Both

Please fill in your Trough Dimensions and Location(s).

**Date**

**Signature**

\_\_\_\_\_

# Trailer Specifications

## Center Partition Worksheet

Please fill out this worksheet to show your new or existing trailer specifications. This will help us understand your situation so we communicate more effectively.

Trailer/Body Manufacturer: \_\_\_\_\_

New Trailer/Body  Existing Retro Fit

Trailer/Body Length: \_\_\_\_\_'

Trailer/Body Width:

96"  102"  Other \_\_\_\_\_"

Type of main refrigeration unit:

Number of remote evaporators (if any): \_\_\_\_\_

(Please sketch location of evaporator(s) at right.

Dimensional detail is helpful.)

Does the Trailer/Body have any side doors?

No  Yes How many \_\_\_\_\_

(Please sketch location of door(s) at right. Again, dimensional detail is helpful.)

Floor Type:  Duct  Smooth

Type of Rear Door(s):  Swing

Roll-up  Roll-up w/cavity

Number of temperature zones required:

Two  Three  Four

Would you like your Center Partitions to be:

Moveable (greatest configuration flexibility)

Fixed Modular Panels

What is the overall length of center wall you require? \_\_\_\_\_"

Will the partition go all the way to the front wall?  Yes  No

Please sketch the configuration layout you have in mind on the drawing. The dashed line is only a guideline.

If you would like our recommendations check here:

Questions?

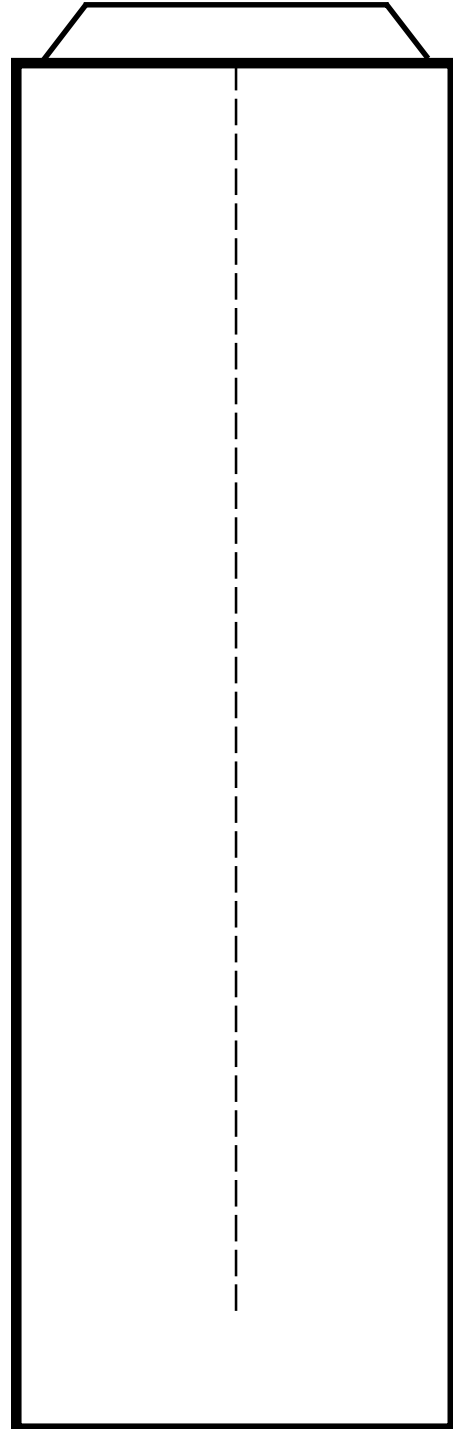

Fax It Back To Us: 1-715-736-0989  
Email It To Us: [sales@fgproducts.com](mailto:sales@fgproducts.com)